



## Savant® IP Audio Products with Integrated Host Deployment Guide

Document Number: 009-1839-08  
Document Date: July 2021  
Document Supports: da Vinci 9.1 or higher

This document will guide the installer through the process of installing, configuring, and adding Savant IP Audio Products with Integrated Host to a RacePoint Blueprint™ configuration.

- IP Audio 1 with Integrated Host and Savant Music [HST-SIPA1SM]
- IP Audio Studio 46 with Integrated Host [HST-STUDIO46-2CH]
- IP Audio Studio 55 with Integrated Host [HST-STUDIO55-2CH]
- Smart Audio WiSA Soundbar [HST-STUDIO55WS-SUR]

# Contents

To access links to the topics within this document, click the corresponding entry in the table below.



1. Before You Begin .....	4	6. Savant Music .....	22
2. Deployment Steps .....	4	7. Web User Interface (Web UI) .....	23
3. Wiring and Connections.....	5	7.1. Accessing the Web UI .....	23
3.1. IR Wiring.....	5	7.2. Status Tab.....	24
3.2. RS-232 Wiring .....	5	7.3. Network Tab.....	24
3.3. Network Connection.....	6	7.4. Inputs & Outputs Tab.....	25
Wired Connection.....	6	HST-SIPA1SM .....	25
Wireless Connection (HST-STUDIO55WS-SUR only).....	6	HST-STUDIOxx-2CH .....	26
3.4. Audio Connections .....	6	HST-STUDIO55WS-SUR.....	27
HST-SIPA1SM .....	6	7.5. Calibration Tab .....	28
HST-STUDIOxx-2CH .....	6	7.6. Firmware Tab (Host <-> Subordinate Settings) .....	29
HST-STUDIO55WS-SUR.....	6	Appendix A: Network Requirements .....	30
3.5. WiSA .....	7	Device Network Connections.....	30
3.6. Power .....	7	AVB Requirements .....	30
3.7. Checking and Replacing the Fuse .....	7	Managing IP Addresses .....	30
4. Installation.....	8	Network Changes .....	30
4.1. HST-SIPA1SM.....	8	Appendix B: System Monitor - Savant Music Trim .....	31
4.2. Host Soundbars .....	9		
HST-STUDIOxxBG-2CH .....	9		
HST-STUDIO55WS-SUR.....	10		
5. Blueprint Configuration .....	11		
5.1. Replacing a Host in a Configuration .....	12		
5.2. Adding a Host to the Layout Window .....	13		
5.3. Adding an IP Audio Product Profile.....	14		
5.4. AVB Speaker Grouping .....	15		
5.5. Advanced Speaker Grouping.....	17		
Surround Grouping Example: .....	17		
Stereo Grouping Example:.....	20		
5.6. Adding a Doorbell or Door Station .....	22		

## Important Safety Information - Read First



Before installing, configuring, or operating any equipment, Savant recommends that each dealer, integrator, installer, etc. access and read all relevant technical documentation. Savant technical documentation can be located by visiting Savant.com. Vendor documentation is supplied with the equipment.

**Read and understand all safety instructions, cautions, and warnings in this document and the labels on the equipment.**

### Safety Classifications In this Document

<b>NOTE:</b>	Provides special information for installing, configuring, and operating the equipment.
 <b>IMPORTANT!</b>	Provides special information that is critical to installing, configuring, and operating the equipment.
 <b>CAUTION!</b>	Provides special information for avoiding situations that may cause damage to equipment.
 <b>WARNING!</b>	Provides special information for avoiding situations that may cause physical danger to the installer, end user, etc.

### Electric Shock Prevention

 <b>ELECTRIC SHOCK!</b>	The source power poses an electric shock hazard that has the potential to cause serious injury to installers and end users.
 <b>ELECTRICAL DISCONNECT:</b>	The source power outlet and power supply input power sockets should be easily accessible to disconnect power in the event of an electrical hazard or malfunction.

### Weight Injury Prevention

 <b>WEIGHT INJURY!</b>	Installing some of the Savant equipment requires two installers to ensure safe handling during installation. Failure to use two installers may result in injury.
---	--

## Safety Statements

All safety instructions below should be read, understood, and applied under all relevant circumstances when working with this equipment.

1. Read these instructions.
2. Keep these instructions.
3. Heed all warnings.
4. Follow all instructions.
5. Do not use this apparatus near water.
6. Clean only with dry cloth.
7. Do not block any ventilation openings. Install in accordance with the manufacturer's instructions.
8. Do not install near any heat sources such as radiators, heat registers, stoves, or other apparatus (including amplifiers) that produce heat.
9. Do not defeat the safety purpose of any polarized or grounding-type plug. A polarized plug has two blades with one wider than the other. A grounding type plug has two blades and a third grounding prong. The wide blade or the third prong is provided for your safety. If any provided plug does not fit into your outlet, consult an electrician for replacement of the obsolete outlet.
10. Protect any power cord from being walked on or pinched; particularly at plugs, convenience receptacles, and the point where they exit from the apparatus.
11. Use only attachments/accessories specified by the manufacturer, following all relevant safety precautions for any such attachments/accessories.
12. Disconnect any outlet powered apparatus from its power source during lightning storms or when unused for long periods of time.
13. Refer all servicing to qualified service personnel. Servicing is required when the apparatus has been damaged in any way, such as a damaged power supply cord or plug, liquid being spilled or objects having fallen into the apparatus, the apparatus being exposed to rain or moisture, apparatus having been dropped, or other failure to operate normally.
14. To completely disconnect equipment from AC mains power, disconnect the power supply cord plug from the AC receptacle.
15. For applicable equipment, use the included power cord with the grounding prong intact to insure proper grounding of the device.
16. For any hardwired or fixed in-wall apparatus, carefully follow all wiring diagrams and instructions. All electrical wiring and servicing should be performed by a properly licensed electrician.

# 1. Before You Begin

Read through this document in its entirety and ensure that the following required items are available:

- Unique ID (UID) of the Savant IP Product with Integrated Host.....
- Savant Development Environment (SDE/MacBook).....
- For minimum supported RacePoint Blueprint da Vinci release, see table below for details.
- Ethernet network meeting Savant requirements.....
- See [Appendix: Network Requirements](#)
- Host <-> Subordinate Mode Settings .....

 **IMPORTANT!** Converting a device from Host Mode to Subordinate Mode MUST be completed before it is placed on the same network as the Savant Host that has its UID in its configuration.  
See [Firmware Tab](#)

## Supported Release

Device	Minimum Supported Release
HST-STUDIOxx-2CH	da Vinci 9.1
HST-SIPA1SM	da Vinci 9.2
HST-STUDIO55WS-SUR	da Vinci 9.2

Feature	Minimum Supported Release
Audio Interrupt Service (AIS)	da Vinci 9.2
Convert to Subordinate	da Vinci 9.2
Advanced Speaker Grouping	da Vinci 9.3

# 2. Deployment Steps

Follow these steps to successfully deploy a Savant Product with Integrated Host. This page can be used as a checklist to record which steps have been completed.

- Review product specifications and connection details.....
- See the device's Quick Reference Guide on the [Savant Customer Community](#).
- Install the Savant IP Audio Studio with Integrated Host.....
- See [Installation](#)
- Add the Savant IP Audio Studio with Integrated Host into a RacePoint Blueprint™ configuration.....
- See [Blueprint Configuration](#)

 **IMPORTANT!** When using the Smart Audio WiSA Soundbar the Frequency Crossover, Slope, and Speaker Distance must be set for optimum performance. For more information on this and recommended settings see [Calibration Tab](#)

### 3. Wiring and Connections

The control connections on the Savant IP Audio Products with Integrated Host are used to send control data to component devices, and/or receive data from devices to display current status information within a user interface, or to trigger a system action. Each port type may support multiple protocols that are determined by the logical connection within Blueprint.

#### 3.1. IR Wiring

IR connections are made using a 6-pin screw down plug-in connector supplied with the controller. The stripped wire slips into the rear of the connector and the screws are used to lock the wire in the hole.

 **IMPORTANT!**

Read precautions below before proceeding!

- All IR emitters must be installed 15 feet (4.6 meters) or less from the chassis or receiver being controlled.
- Use of 3rd party flashing IR emitters with Talk Back is not recommended. These types of emitters can draw voltage away from the IR signal which degrades the IR performance.

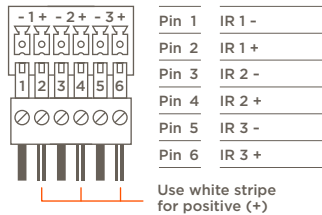

To connect wires into terminal block connector:

1. Remove power if power is applied.
2. Pull to remove the connector from the rear of the controller.
3. With a small flat bladed screwdriver, turn the screws on the top of connector counterclockwise until the silver crimps in the front open enough to slide the wire into the square slot.
4. Strip the ends of each wire to ¼ inch. Using the diagram to the left, insert the stripped wires into the proper slots.
5. Turn the screws clockwise until the screw tightens around each wire. Tug on the wire a bit to verify it is installed securely. There should no bare wires protruding from the rear of the connector.
6. Plug terminal block back into the rear of the controller.

#### 3.2. RS-232 Wiring

RS-232 connections are made using a 6-pin screw down plug-in connector supplied with the controller. The stripped wire slips into the rear of the connector and the screws are used to lock the wire in hole.

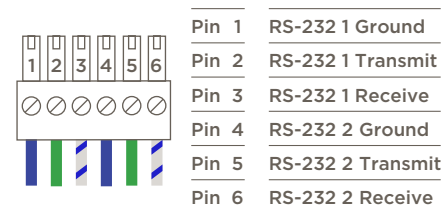

**NOTES:**

- Wire colors shown do not represent any standard.
- CTS/RTS handshaking for flow control is not supported.
- For further details on RS-232 serial control adapters, conversion, and wiring, refer to the RS-232 Conversion to DB-9 and RS-422/485 Pinout Reference Guide and/or the RS-232 Serial Communication Troubleshooting Guide on the [Savant Customer Community](#).

To connect wires into the terminal block connector:

1. Remove power if power is applied
2. Pull to remove the terminal block from rear of the controller.
3. With a small flat bladed screwdriver, turn the screws on the top of the terminal block counterclockwise until the silver crimps in the front open enough to slide the stripped wires into the square slots.
4. Insert one of the stripped wires from the device being controlled into its respective slot on the terminal block. Refer to the diagram.
5. Turn the screw clockwise until the silver crimp tightens around the wire. Tug on the wire a bit to verify the wires are installed securely. Make sure a minimal amount of bare wire is exposed to prevent contact between adjacent wires.
6. Repeat for each wire till all wires are installed and plug terminal block back into the rear of the controller.
7. Reapply power.

### 3.3. Network Connection

#### Wired Connection

Savant IP Audio devices use a standard RJ-45 port complying with IEEE 802.3 Ethernet standards. This port also supports Audio Video Bridging (AVB) or Time Sensitive Networking (TSN) over Ethernet (AVB/TSN, IEEE 802.1). Up to 45 IP Audio devices can be connected using AVB/TSN compliant switching. For more information, see [Appendix: Network Requirements](#).

#### Wireless Connection (HST-STUDIO55WS-SUR only)

The Smart Audio WiSA Soundbar contains a Wireless radio. Wireless connectivity is only available when operating in Host mode. Provisioning can be done with the Savant SmartConnect App. For more information see the SmartConnect Software Reference Guide on the [Savant Customer Community](#).

### 3.4. Audio Connections

#### HST-SIPA1SM

##### Speaker Output

- Single zone speaker output. Uses included 4-pin speaker connector.
- Supports 8 ohm or 4 ohm speakers.

##### Analog Audio Input/Outputs

- 2-channel analog stereo connection (RCA)

##### Digital Audio Input

- Digital optical audio inputs (TOSLINK). Supports up to 192kHz/24-bit digital audio in; PCM stereo format only.

#### HST-STUDIOxx-2CH

##### Digital Audio Input

- Digital optical audio inputs (TOSLINK). Supports up to 192kHz/24-bit digital audio in; PCM stereo format only.

#### HST-STUDIO55WS-SUR

##### Digital Audio Input

- The Optical Input (TOSLink) support up to 192kHz/24-bit digital audio and up to 5.1 encoded audio.



**IMPORTANT!** This connection is required for Surround Sound to be used/transmitted. Other AVB sources can not supply Surround Sound data.

##### Sub Out

- Wired sub-woofer connection. 3.5 mm analog audio connection, Direct line level, 2.1 V<sub>RMS</sub> max.
- This output is always active, there is no connection representation needed in the blueprint configuration.

### 3.5. WiSA

The HST-STUDIO55WS-SUR is WiSA certified. The WiSA setup is done inside the Savant Pro App, for more information on WiSA setup see the Savant WiSA Setup Guide on the [Savant Customer Community](#).

### 3.6. Power

The IP Audio Products have an AC Power connection.



#### **SURGE PROTECTION!**

Use a surge-protected circuit for all components and power supplies requiring 100/240V (AC 50/60 Hz) source power.



#### **ELECTRICAL DISCONNECT!**

The source power outlet and power supply input power sockets should be easily accessible, to disconnect power in the event of an electrical hazard or malfunction.

### 3.7. Checking and Replacing the Fuse

To check or replace the HST-SIPA1SM-xx fuse, carefully follow the instructions below:



#### **ELECTRIC SHOCK HAZARD:**

This device must be disconnected from AC power by removing the power cord from the AC outlet and the unit before checking or replacing the fuse.

1. Disconnect the unit from AC power by removing the power cord.
2. Remove the fuse cartridge by pulling the tab marked **A** in the image below.
3. Remove the old fuse from the cartridge and discard.
4. Gently clip the new fuse into the cartridge and slide the cartridge part way into the receptacle, ensuring that the alignment is correct.
5. Press cartridge fully into receptacle, ensuring that it is seated and secure.

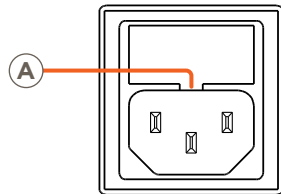

**NOTE:** If any resistance is encountered while seating the cartridge, DO NOT apply more pressure. Stop pressing the cartridge, remove it, verify that the fuse is properly placed and fully seated, align cartridge carefully, and reinsert.

## 4. Installation

### 4.1. HST-SIPA1SM

The IP Audio 1 includes side-mounting brackets for installation in a structured media panel, enclosure, or on a wall. The unit can also be placed on any flat surface, such as a table or shelf, or can be combined with an optional rack mounting kit (RMB-SIPA12F-00) which allows 2 units to be placed side by side in a standard 1U rack mounting.

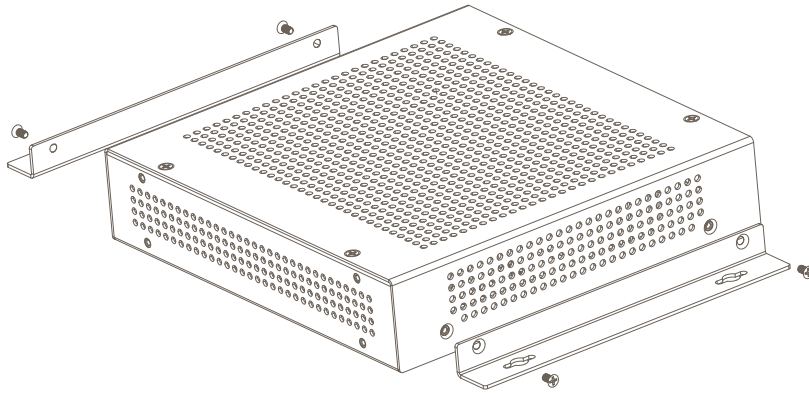

To install the side mounting brackets remove the case screws and attach the brackets to the side of the device as shown above.

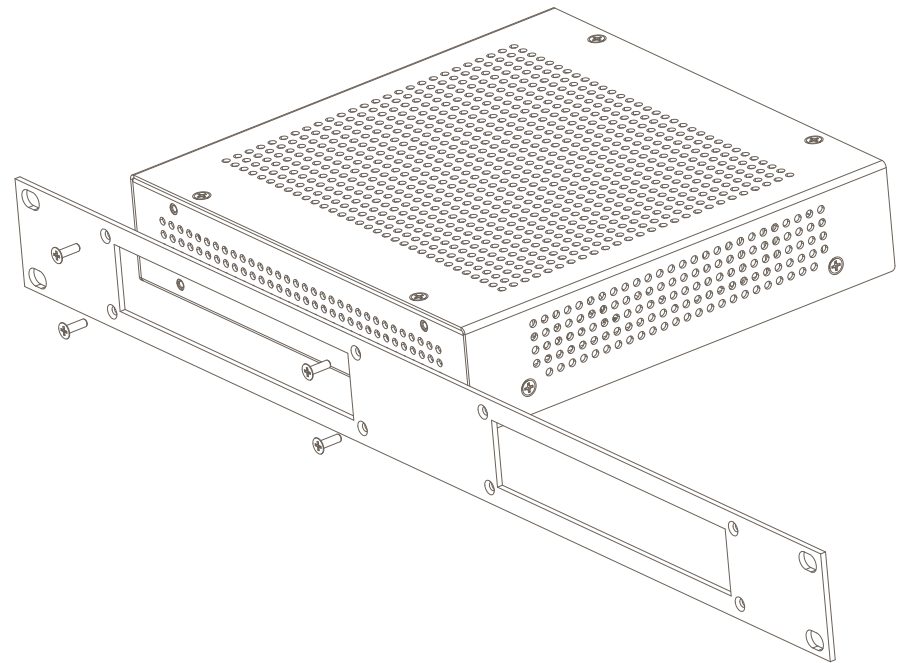

To install the rack mounting bracket use the screws included with the Rack Mounting Kit and attach the bracket to the back of the device as shown above.



## 4.2. Host Soundbars

Savant IP Audio Soundbars ship with wall mount brackets. They can also be installed on a solid, flat, level surface. The location should be dry, well ventilated, and out of direct sunlight. This section details the installation instructions for wall mounting or using the included feet to have the Soundbar on a flat surface.

### HST-STUDIOxxBG-2CH

#### Wall Mount

**NOTE:** Make all wiring connections to soundbar before mounting to brackets.

1. Identify the location that the Soundbar will be mounted.
2. (Optional) Locate the wall studs. Savant recommends anchoring the wall mounts into wall studs. This is the ideal way to support the weight of the Soundbar.
3. Space out the wall mounts allowing sufficient space between brackets to ensure stability. Savant recommends the wall mounts be placed approximately 1/3 of the way from the ends of the Soundbar.
4. Using appropriate fasteners to support the weight of the soundbar, affix wall mounting brackets to the wall, allowing sufficient space between brackets to ensure stability.
5. If utilizing the included bracket extensions, connect to wall mounting brackets using M5x10mm screws.
6. Align the captive M5 threaded brackets inside soundbar mounting slide with position of wall mounting brackets.
7. Attach soundbar by threading M5x10mm screws through wall brackets and into the soundbar captive mounting slide brackets.

#### Plastic Feet

1. Align the captive M5 threaded brackets in the soundbar mounting slide beneath the center speakers of right and left side channels.
2. Secure plastic feet to the captive brackets using M5x190mm screws.
3. Remove wax paper from the adhesive backing on included rubber pads and attach one to each of the plastic feet.

## HST-STUDIO55WS-SUR

### Wall Mount

**NOTE:** Make all wiring connections to soundbar before mounting to brackets.

1. Identify the location that the Soundbar will be mounted.
2. (Optional) Locate the wall studs. Savant recommends anchoring the wall mounts into wall studs. This is the ideal way to support the weight of the Soundbar.
3. Space out the wall mounts allowing sufficient space between brackets to ensure stability. Savant recommends the wall mounts be placed approximately 1/3 of the way from the ends of the Soundbar.
4. Using appropriate fasteners to support the weight of the soundbar, affix wall mounting brackets to the wall, allowing sufficient space between brackets to ensure stability.
5. If utilizing the included bracket extensions, connect to wall mounting brackets using M5x10mm screws.
6. Align the captive M5 threaded brackets inside soundbar mounting slide with position of wall mounting brackets.
7. Attach soundbar by threading M5x10mm screws through wall brackets and into the soundbar captive mounting slide brackets.

### Rubber Feet

**IMPORTANT!** The rubber feet must be used with the included grille.

1. Align the foot under the center speaker of the Right/Left Channel.
2. Remove the waxed paper from the adhesive.
3. Attach the foot to the soundbar.
4. Repeat for the second rubber foot.

## 5. Blueprint Configuration

In order to configure the IP Audio Products with Integrated Host within Blueprint for use as both a Savant System Host and an IP Audio device, it must be added to the configuration and Layout Window twice. Within the Component Profile Library, there are two Profiles for each component available. For example the HST-SIPA1SM Profile should be added as the Savant Host, then dragged and dropped into the Layout Window to represent the device's Host function. The PAV-SIPA1SM Profile must then be added to the configuration and Layout Window for the component to function as an IP Audio device. Both Profiles should be populated with the same Savant UID within Inspector. The example images below show simple Blueprint configurations with both Host and IP Audio Profiles added as described:

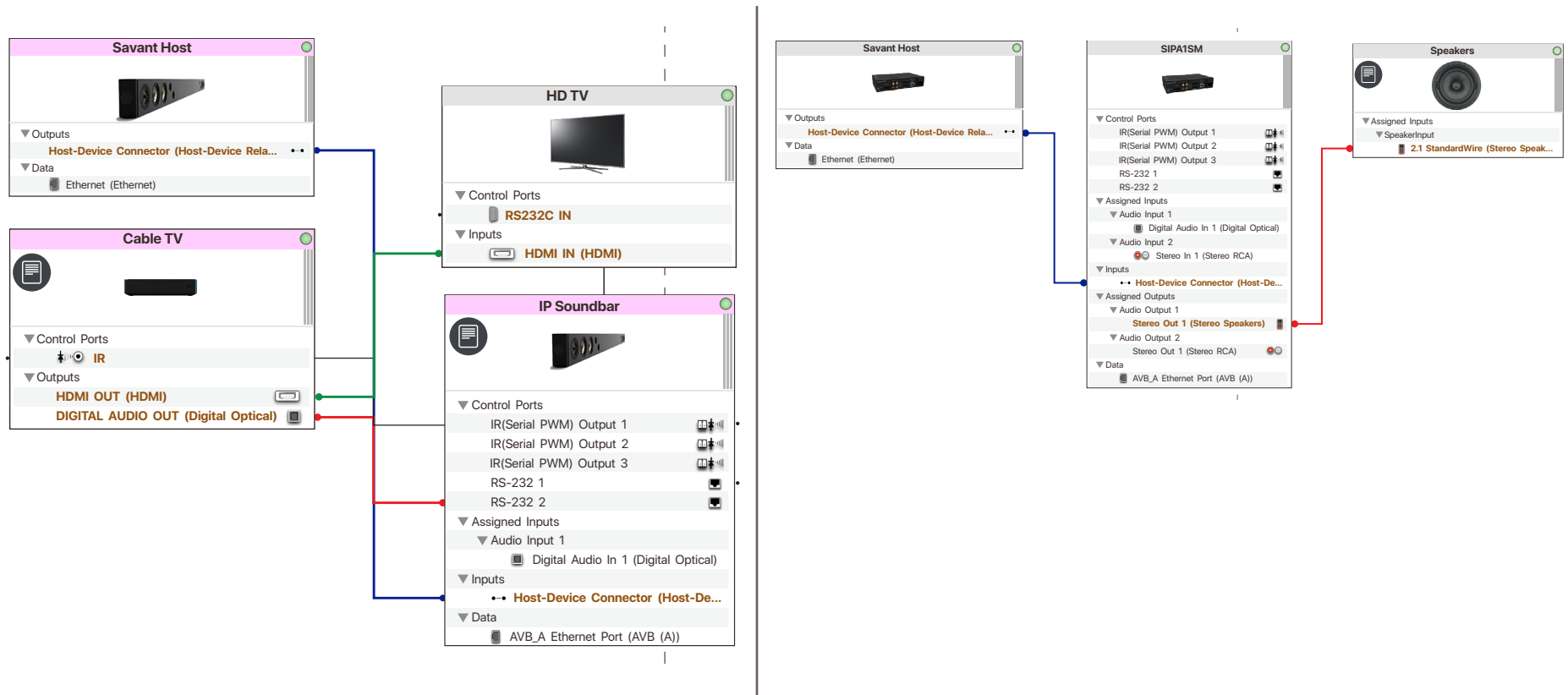

## 5.1. Replacing a Host in a Configuration

By default, a Savant Pro Host is added to any new RacePoint Blueprint configuration file. When utilizing one of the other varieties of Savant Host, including the HST-SIPA1SM or HST-STUDIOxx-2CH, the existing Host Profile must be replaced with the one matching the device used on site. The example below shows how to configure the HST-SIPA1SM as the Savant System Host.

1. In an open Blueprint configuration, open the Component Library by navigating to:  
**View > Show Component Library**
2. Enter HST-SIPA1SM into the Search field.
3. Select the HST-SIPA1SM profile from the list and drag it onto the Host in the left side Component List.
4. Select **Replace** when prompted.
5. At the top of the Component List, select the Host and drag it into the Layout Window.
6. Enter a unique Device Name and the Savant UID for the Host.  
The Savant UID is used to identify the Host on the network so that a configuration may be uploaded.
  - A. Select the Host in the Layout Window and open the Inspector by navigating to:  
**View > Show Inspector**
  - B. Enter a Device Name that is unique to the system.
  - C. Enter the Savant UID for the host.

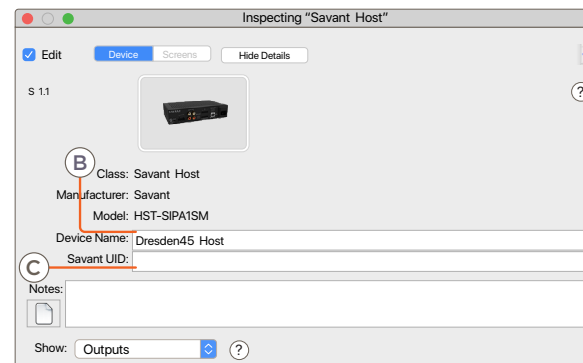
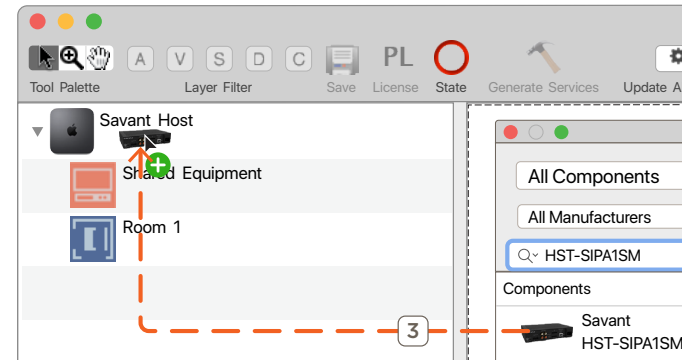

### TIPS:

- Savant recommends using the customer's last name and a number unique to the customer followed by Host. Example: Dresden45 Host
- Host names exceeding 20 characters, or utilizing special characters (such as &, %, @, #, etc.) may cause certain types of communication issues, and are therefore not recommended by Savant.

## 5.2. Adding a Host to the Layout Window

This section outlines the process of configuring a HST-SIPA1SM as the system Host when it has already been added as the Host in the component list, or is the default Host for the configuration. The process follows the same steps for other IP Audio Products with Integrated Host..

Follow the steps below:

1. In an open Blueprint configuration, select the Host at the top of the Component List and drag it onto the Layout Window.
2. Enter a unique Device Name and the Savant UID for the Host.  
The Savant UID is used to identify the Host on the network so that a configuration may be uploaded.
  - A. Select the Host in the Layout Window and open the Inspector by navigating to:  
View > Show Inspector
  - B. Enter a Device Name that is unique to the system.
  - C. Enter the Savant UID for the Host.



### TIPS:

- Savant recommends using the customer's last name and a number unique to the customer followed by Host. Example: Dresden45 Host
- Host names exceeding 20 characters, or utilizing special characters (such as &, %, @, #, etc.) may cause certain types of communication issues, and are therefore not recommended by Savant.

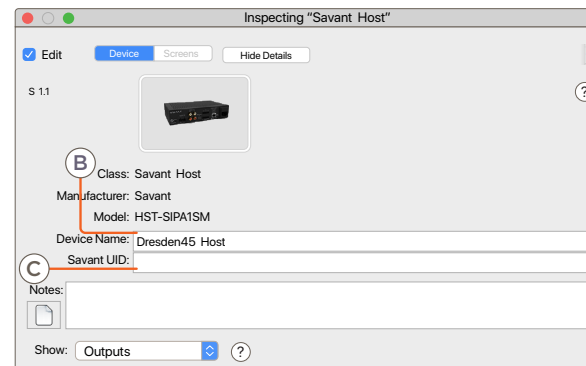
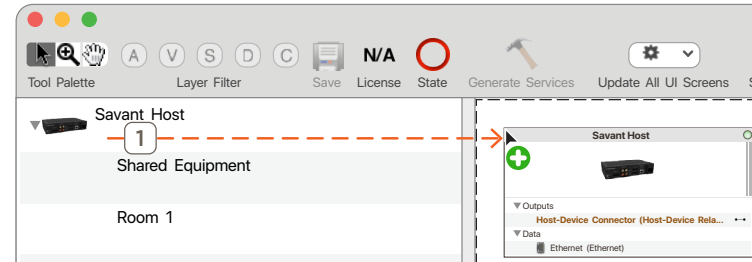

### 5.3. Adding an IP Audio Product Profile

The steps outlined in this section detail the process for adding and configuring the PAV-SIPA1SM Profile within Blueprint. The process for adding the second Profile with other IP Audio Products with Integrated Host follows the same steps using the corresponding IP Audio Profile for each device. This second Profile is required in order to utilize the device's control and audio connections within the configuration.

1. Click Show Library.
2. Search for PAV-SIPA1SM (or the IP Audio device Profile matching the product in use).
3. Select the IP Audio 1 and drag into a User zone.
4. Name the device.
5. Place the IP Audio 1 in the Layout window.
6. Select the IP Audio 1.
7. Open Inspector.
8. Enter UID.

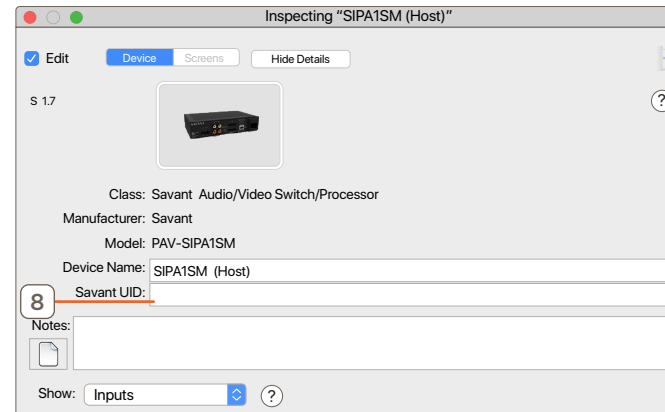
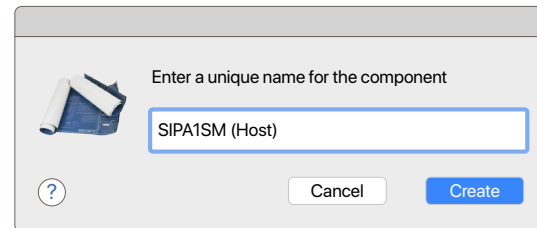
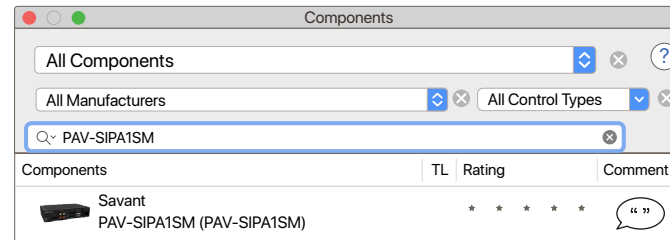

For more information on using the IP Audio Product with Integrated Host in a system with other AVB devices, see the Savant IP Audio Speaker and Soundbar Deployment Guide or the Savant IP Audio Deployment Guide on the Savant Customer Community.

## 5.4. AVB Speaker Grouping

If there is more than one AVB Audio endpoints in the same User zone, Blueprint will generate service path options that group them and use them as a single audio service.

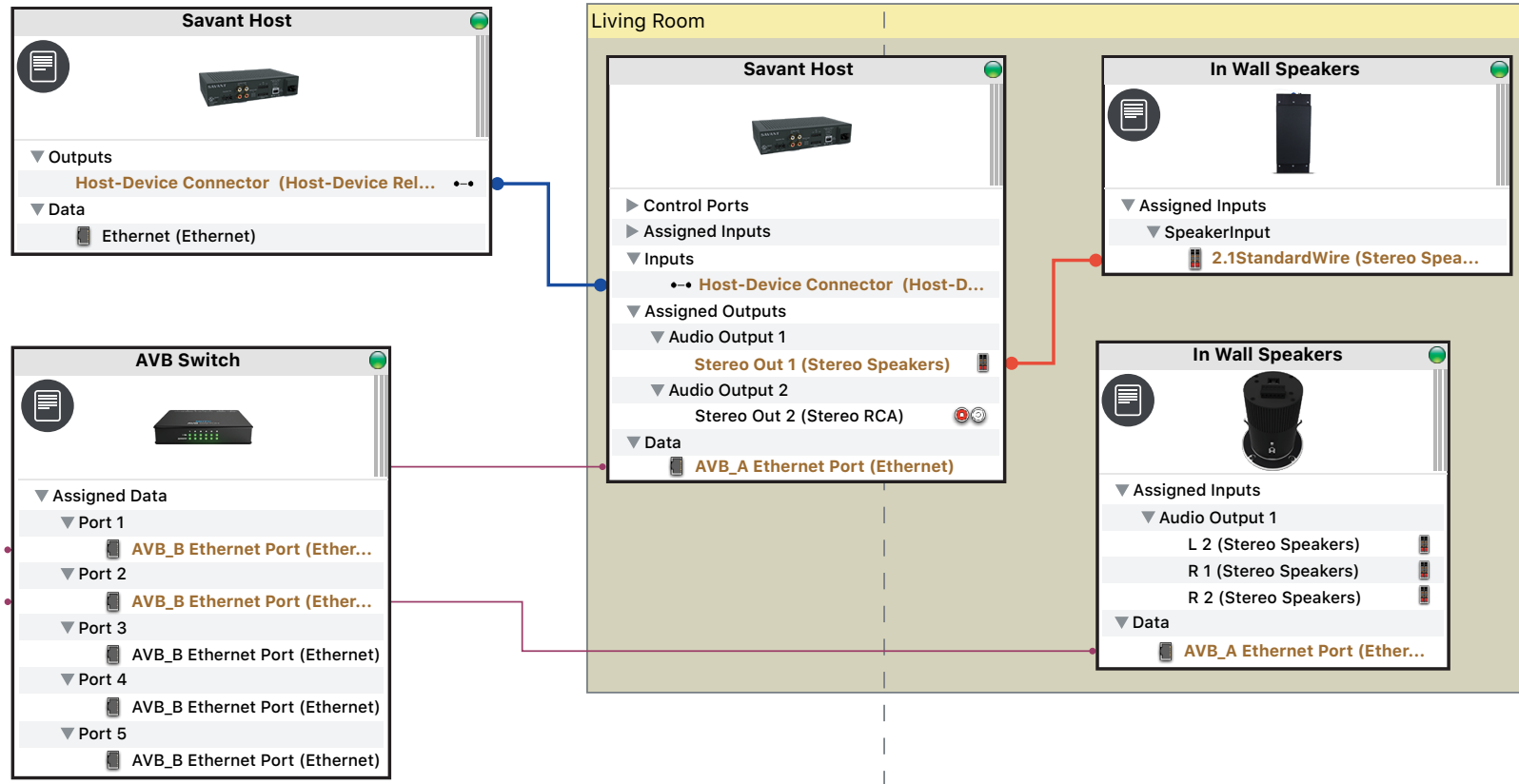

Below is an image of the Services window for the Savant Music service in the example shown above. It is included to highlight the service path of this service.

The screenshot shows the 'Services for Dresden Residence' window. The 'Service Resources' tab is active, displaying a tree view of resources. The 'Audio' resource is expanded, showing 'SIPA1SM' selected. Under 'SIPA1SM', there are two paths: 'SIPA1SM' and 'AVB Switch'. The 'SIPA1SM' path includes 'Savant Music Source', 'Audio Switch Function', 'Volume Control Function', 'Stereo Audio Processor Function', and 'Amplifier Function'. The 'AVB Switch' path includes 'Passive Input', 'Passive Output', and 'AVB Speakers'. Red lines connect these paths to labels: 'Audio Source' points to the top 'SIPA1SM' path, 'In Wall Speaker Audio Path' points to the 'SIPA1SM' path, and 'AVB Speakers (In Ceiling) Audio Path' points to the 'AVB Switch' path.

## Allow Independent Services

The screenshot shows the 'Inspecting Family Room' window. The 'Edit' tab is active, showing fields for 'Zone Name: Family Room', 'Master Name: Dresden Residence', 'Type: User', and 'Preferred Audio Source: None'. There are three checkboxes: 'Ignore Audio Services Paths For AV Services', 'Allow Independent Services', and 'Allow Independent Services With Managed Audio'. The 'Allow Independent Services' checkbox is checked.

**Allow Independent Services** - Allows more than one service to be active at once. When there is more than one audio endpoint in the zone they could be playing different audio at the same time.

**Allow Independent Services with Managed Audio** - Allows more than one service to be active at once. When there is more than one audio endpoint in a zone this will deactivate any other audio service in the zone. Leaving the last activated services audio playing.



## 5.5. Advanced Speaker Grouping

Systems running da Vinci 9.3 and higher can access the Pro Audio Control table within Blueprint for configuration of AVB speaker grouping. This table allows speaker groups to be pre-defined on a zone by zone basis. Blueprint will then generate service paths tailored to each defined group, making them easier for the user to discern and select from the view services window.

Additionally, user zones that include STUDIO55WS soundbars can use the grouping defined within the Pro Audio Control table to create speaker groups for surround sound. STUDIO55WS soundbars are capable of decoding bitstream content routed through their local TOSlink input, enabling passive speakers and hardwired subwoofer endpoints driven by Savant AVB chassis and grouped with the STUDIO55WS soundbar to receive decoded surround channel and LFE content.

### Surround Grouping Example:

1. Open the Pro Audio Control window.  
**Tools > Settings > Pro Audio Control...**
2. Select the zone to be programmed.

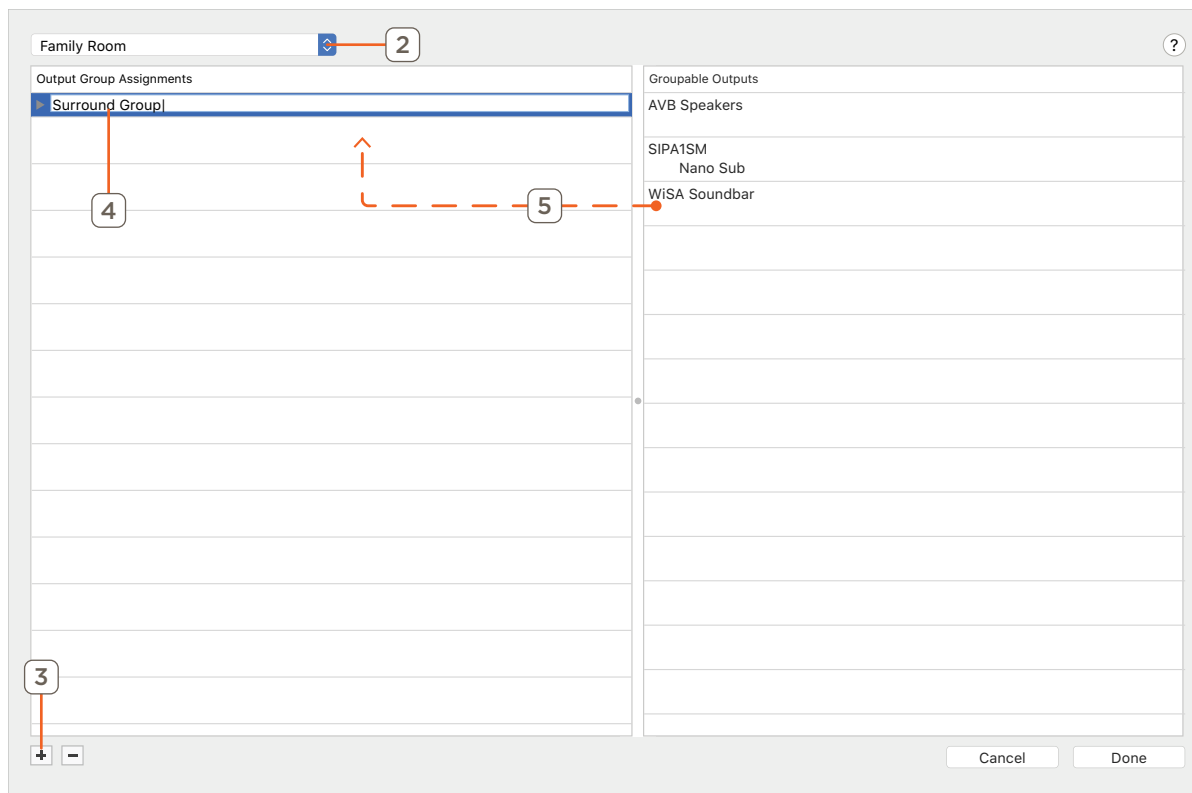

3. Click the + button to create a new Group.
4. Name the Group.  
This group name will become a part of the service variant for service path selection in the view services window.
5. Click and drag the desired speaker(s) into the group.

6. Repeat step 5 for each speaker(s) in the group.
7. Select Surround channel type.

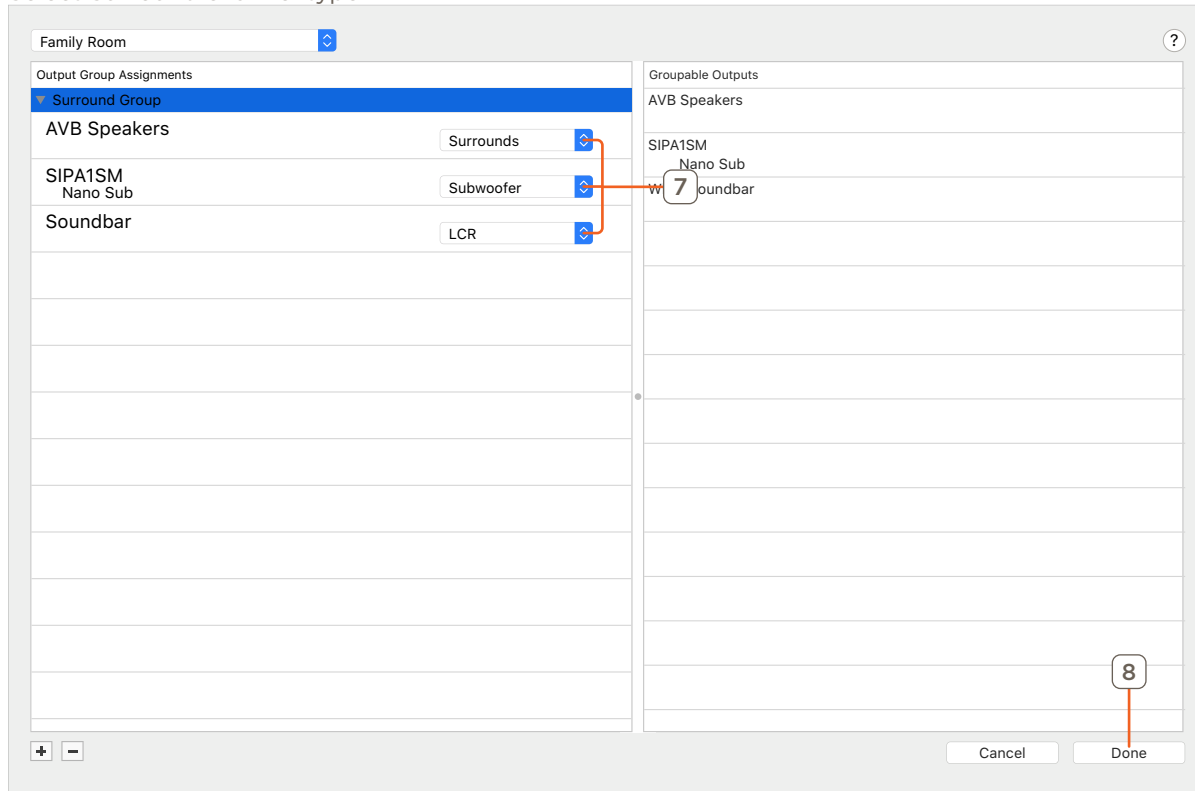

8. Click Done.
9. Generate Services.

**! IMPORTANT!**

- The speaker type options are only available when the group contains a Smart Audio Soundbar (HST-STUDIO55WS or IP-STUDIO55WS).
- In this example, LFE (subwoofer) content is passed to the Right channel output port of the RCA stereo connection configured for the subwoofer.
- A TOSLink connection to the Soundbar is required to transmit Surround Sound audio. This connection must contain Surround Sound data and no other AVB sources can supply Surround Sound data. An example of this would be to have the TV receive Surround Sound data from its HDMI source and output it via Digital Output into the Soundbar's TOSLink input.

10. Open the View Services window.
11. Select a zone with defined AVB Speaker group(s).

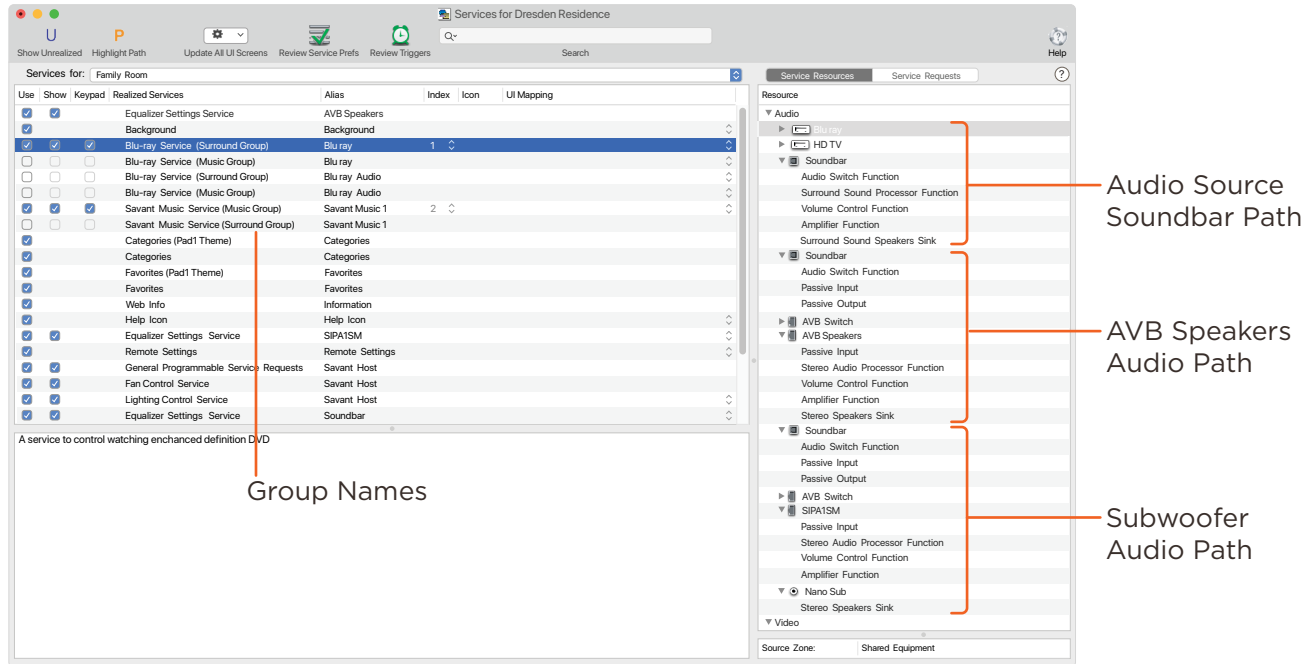

12. Review the service paths and select the desired Speaker group for each service in the zone.

### Stereo Grouping Example:

1. Open the Pro Audio Control window.  
**Tools > Settings > Pro Audio Control...**
2. Select the zone to be programmed.

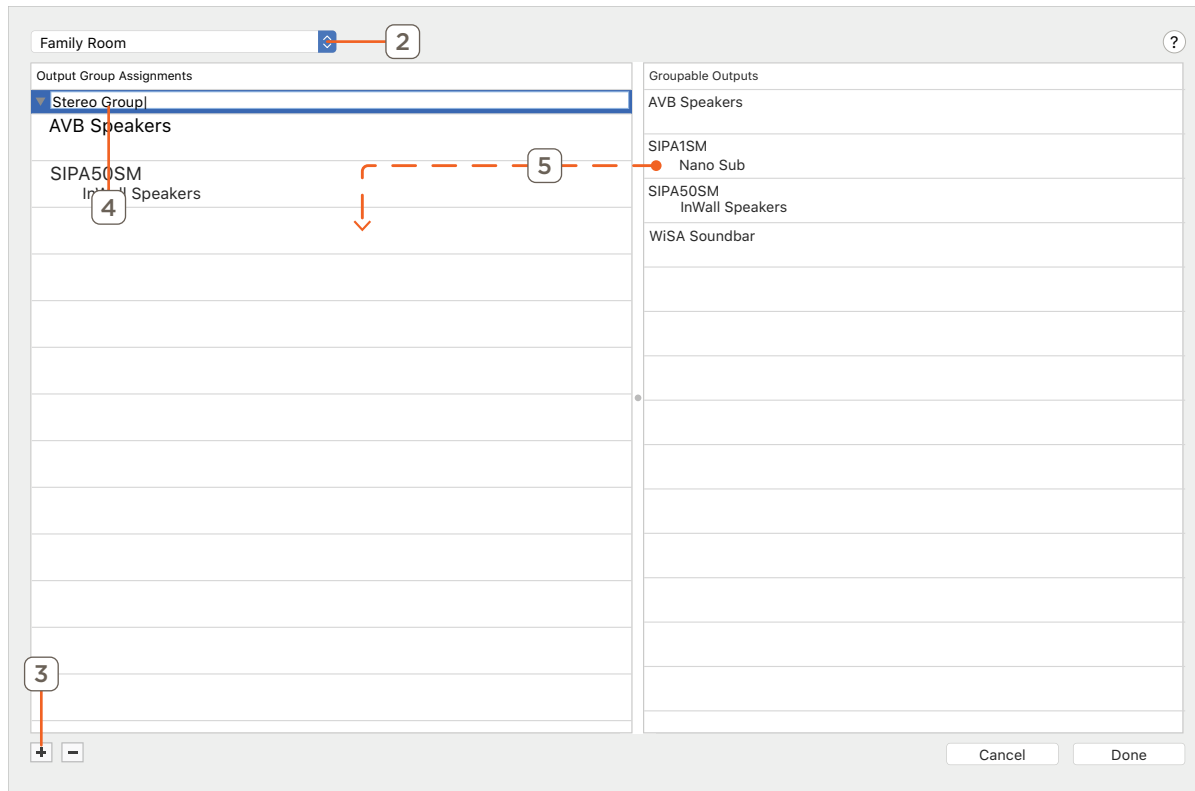

3. Click the + button to create a new Group.
4. Name the Group.  
This group name will become a part of the service variant for service path selection in the view services window.
5. Click and drag the desired speaker(s) into the group.

6. Repeat step 5 for each speaker(s) in the group.
7. Click Done.
8. Generate Services.
9. Open the View Services window.
10. Select a zone with defined AVB Speaker group(s).

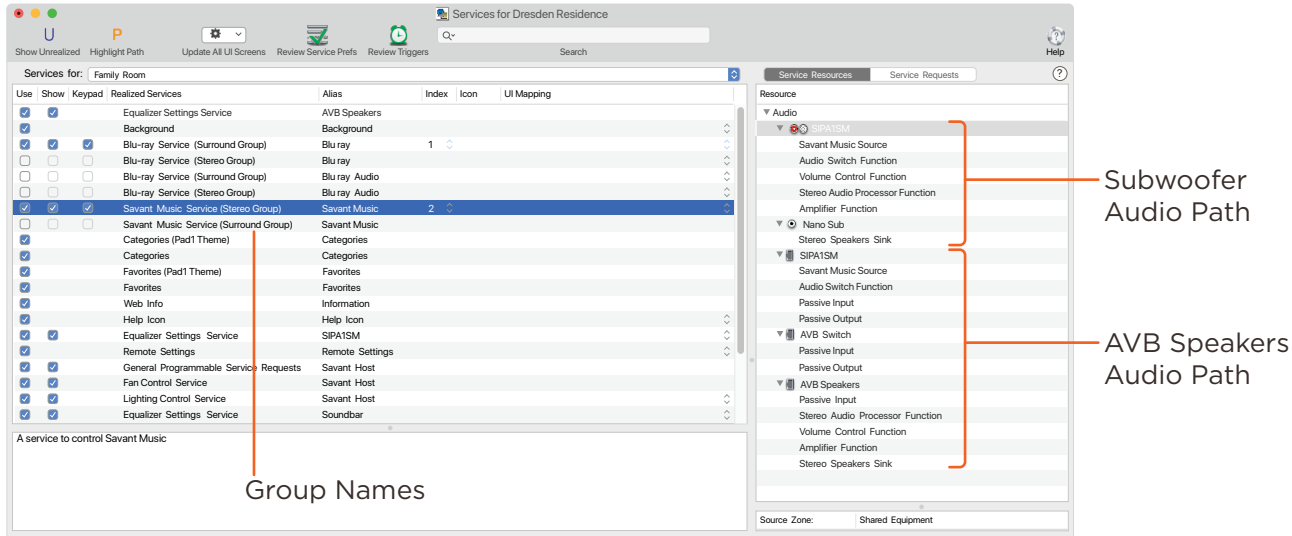

11. Review the service paths and select the desired Speaker group for each service in the zone.

## 5.6. Adding a Doorbell or Door Station

The Savant IP Audio Products with Integrated Host supports the Audio Interrupt Service (AIS), which is used to interrupt the currently playing audio with a doorbell chime a doorbell chime to alert the user that a doorbell has been pressed. This service requires a connection between Host profile and the IP Audio profile. This is a special connection.

To make this connection do the following:

1. Select the Host Profile.
2. Right Click on the Host-Device Connection.
3. Select the PAV-SIPA1SM Profile with the same UID as the Host.

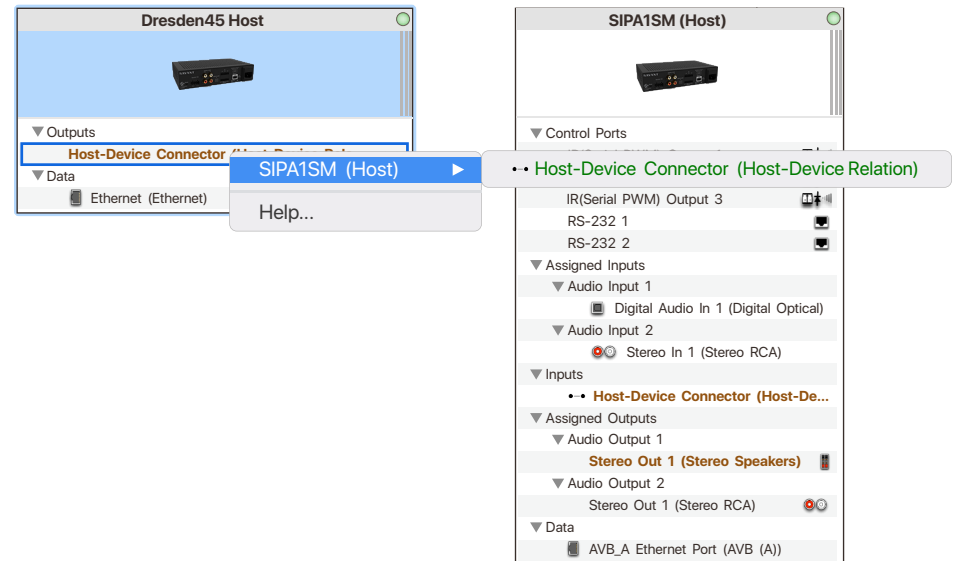

### HELPFUL INFO

If the Host-Device Connection is made to a profile that has a different UID than the Host, the interrupt will happen but no sound will be heard.

For more information on AIS see the Audio Interrupt Service (AIS) Programming Guide located on the [Savant Customer Community](#) for information on using AIS.

## 6. Savant Music

The IP Audio Products with Integrated Host include a single stream of Savant Music. This allows the use of popular music streaming services such as Pandora or Spotify (streaming music service fee may apply). For a full list of supported services, see Savant Media Server/Savant Music Supported Streaming Services on the [Savant Customer Community](#).

The service is generated in Blueprint. The streaming services are managed in the Savant Pro App.

## 7. Web User Interface (Web UI)

Savant IP Audio devices have an available Web UI, which includes options for control and real-time management of audio connections, as well as a number of device settings. This can be especially useful for troubleshooting potential issues in the field.

### 7.1. Accessing the Web UI

In order to access the Web UI, the IP Address of the IP Audio device is needed. This can be obtained from System Monitor, rpmEmpScanner, or any network scanning software.

1. On the SDE, open a Web Browser and enter the address of the device in the address bar:  
Syntax: `http://[IP Address of Device]`

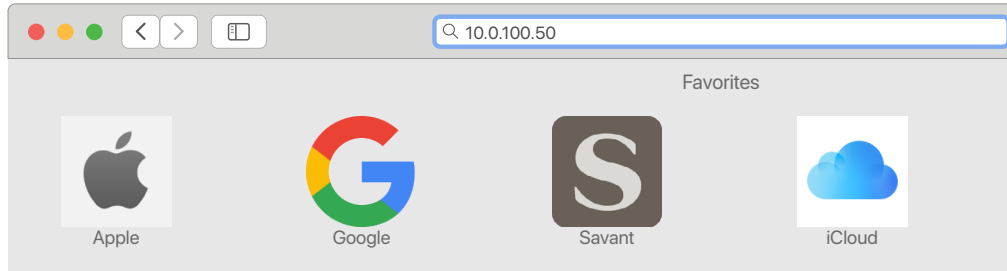

2. Once opened, login credentials will be required:  
Default User Name: RPM  
Default Password: RPM

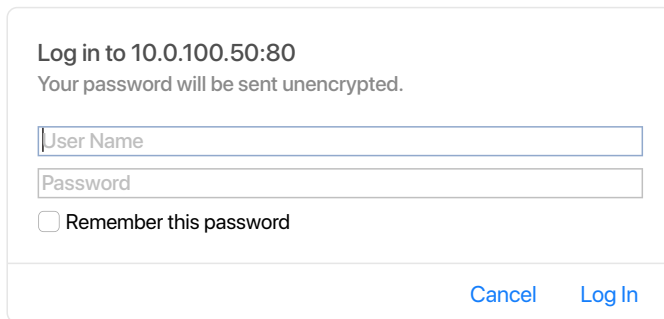
A screenshot of a login page titled "Log in to 10.0.100.50:80". Below the title is a warning: "Your password will be sent unencrypted." There are two input fields: "User Name" and "Password". Below the "Password" field is a checkbox labeled "Remember this password". At the bottom right are two buttons: "Cancel" and "Log In".

3. Select Go To Audio Controller Page.

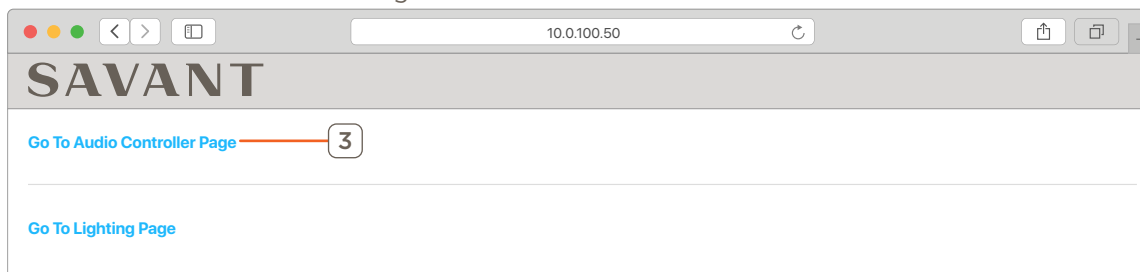

**NOTE:** For information on the Lighting Page see the **System Monitor Reference Guide** section on WiFi Lighting on the [Savant Customer Community](#).

## 7.2. Status Tab

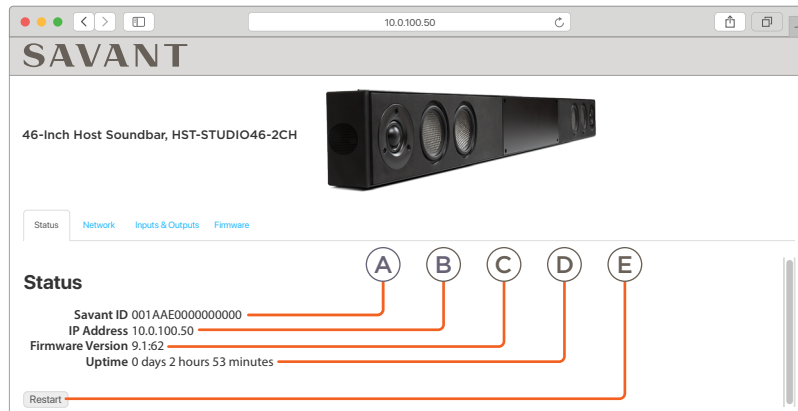

(A) Savant ID	UID of the device.
(B) IP Address	Currently assigned IP Address.
(C) Firmware Version	Current Firmware Version number.
(D) Uptime	Amount of time the unit has been powered without a restart.
(E) Restart	Restarts the software of the unit.

## 7.3. Network Tab

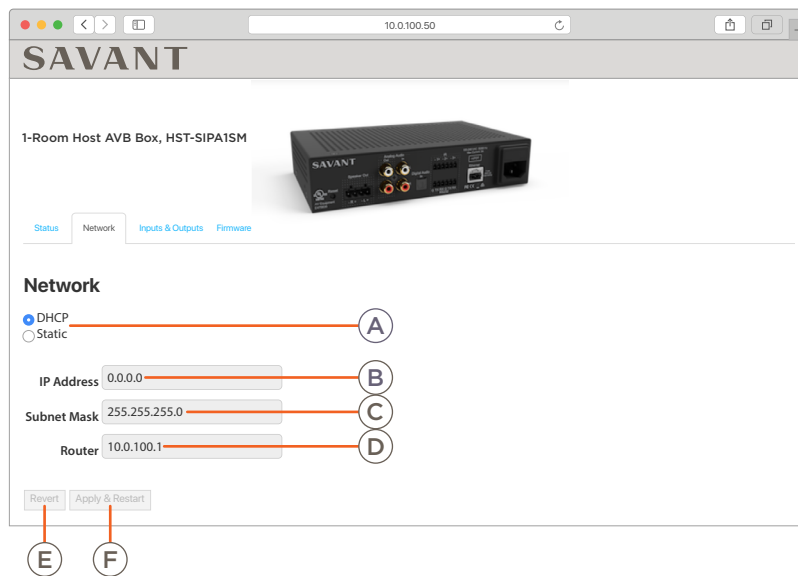

(A) IP Address Configuration	DHCP (Dynamic Host Configuration Protocol) or Static.
(B) IP Address	Displays the current IP Address and allows for entry. This is automatically assigned when item A is set to DHCP.
(C) Subnet Mask	Subnet mask of the network. This is automatically assigned when item A is set to DHCP.
(D) Router	IP Address of the network router. This is also known as Gateway or Default Gateway.
(E) Revert	Select to erase entered settings and revert back to saved settings.
(F) Apply & Restart	Select to apply entered settings, and restart the device.

### NOTE:

Setting the IP Address with a Static Address from the WebUI will automatically set the device's DNS to 8.8.8.8 and 8.8.4.4 (Google).



## 7.4. Inputs & Outputs Tab

### HST-SIPA1SM

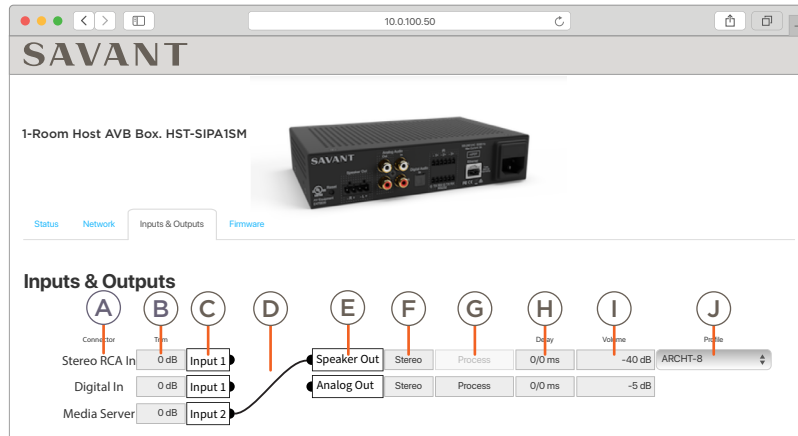

A	Connector Type	Stereo RCA, Digital Input (TosLink) or Media Server. <b>NOTE:</b> Audio paths that originate from a different AVB device do not show here.
B	Channel Trim	Adjusts the gain of the input from -10 dB to +10 dB. For testing or troubleshooting use. Changes made in the WebUI affect local outputs only, and are overwritten during system startup. To permanently adjust trim settings, apply the changes in System Monitor.
C	Input List	List of the inputs on the device.
D	I/O Connection Indicator	Active connections are represented by a black line between the input and output. To connect an input to an output manually from the WebUI, click and drag to draw the connection from the black dot on the input to the black dot on the output.
E	Output List	List of the outputs on the device.
F	Output Channels	Toggle between Stereo and Mono by clicking in this field. Mono Summing combines the left and right stereo output channels into a single speaker channel output.
G	Process	Toggle between Process or Pass-Through, this feature is disabled on the Speaker Out.
H	Delay	Adjustable delay per channel from 0 - 160ms.
I	Volume	Adjusts the volume level of the output channel. For speaker outputs, the possible adjustment range varies across different IP Audio devices. Changes are made in 1 dB increments.
J	Profile	Select from available Speaker Profiles to apply EQ presets for Savant/Artison speakers. This is an advanced feature for audio correction based on room acoustics.

# HST-STUDIOxx-2CH

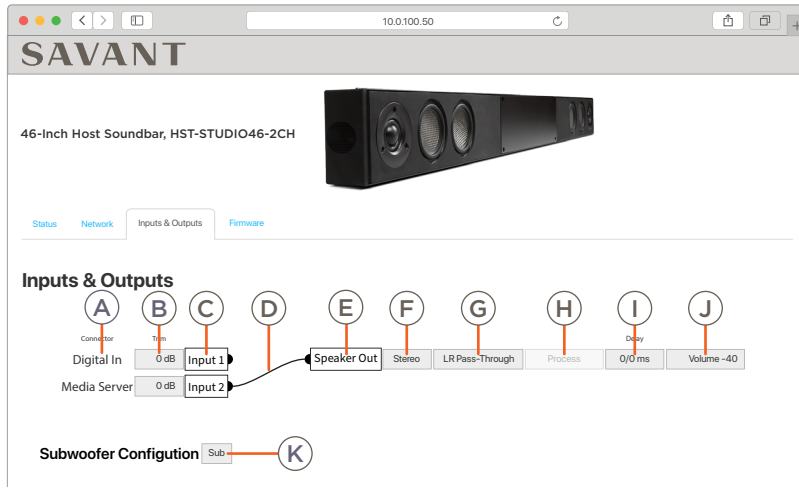

Ⓐ Connector Type	Digital Input (TosLink) or Media Server. <b>NOTE:</b> Audio paths that originate from a different AVB device do not show here.
Ⓑ Channel Trim	Adjusts the gain of the input from -10 dB to +10 dB. For testing or troubleshooting use. Changes made in the WebUI affect local outputs only, and are overwritten during system startup. To permanently adjust trim settings, apply the changes in System Monitor.
Ⓒ Input List	List of the inputs on the device.
Ⓓ I/O Connection Indicator	Active connections are represented by a black line between the input and output. To connect an input to an output manually from the WebUI, click and drag to draw the connection from the black dot on the input to the black dot on the output.

Ⓔ Output List	List of the outputs on the device.
Ⓕ Output Channels	Toggle between Stereo and Mono by clicking in this field. Mono Summing combines the left and right stereo output channels into a single speaker channel output.
Ⓖ Left/Right Channel swap	Toggle between LR Pass-Through and LR Swap. If the Soundbar is mounted on top of a TV or is other wise flipped over this will reverse the Left and Right Channels.
Ⓗ Process	Toggle between Process or Pass-Through, this feature is disabled on the Speaker Out.
Ⓘ Delay	Adjustable delay per channel from 0 - 160ms.
Ⓙ Volume	Adjusts the volume level of the output channel. For speaker outputs, the possible adjustment range varies across different IP Audio devices. Changes are made in 1 dB increments.
Ⓚ Subwoofer Configuration	Toggle on or off. If on it enables a fixed high pass filter at 80Hz.

# HST-STUDIO55WS-SUR

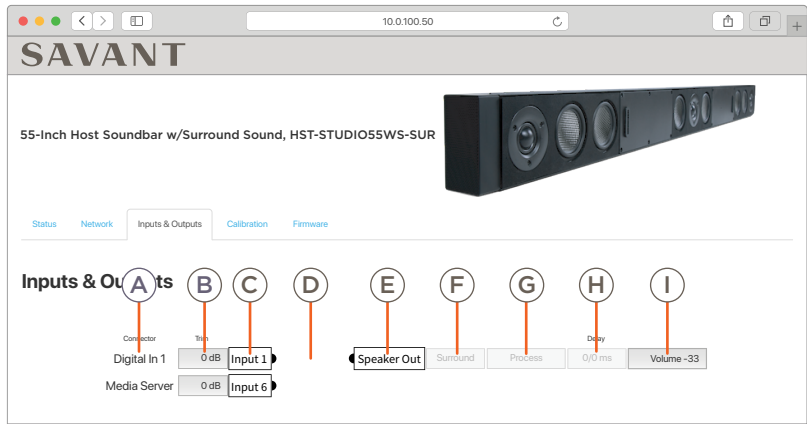

A Connector Type	Digital Input (TosLink) or Media Server. <b>NOTE:</b> Audio paths that originate from a different AVB device do not show here.
B Channel Trim	Adjusts the gain of the input from -10 dB to +10 dB. For testing or troubleshooting use. Changes made in the WebUI affect local outputs only, and are overwritten during system startup. To permanently adjust trim settings, apply the changes in System Monitor.
C Input List	List of the inputs on the device.
D I/O Connection Indicator	Active connections are represented by a black line between the input and output. To connect an input to an output manually from the WebUI, click and drag to draw the connection from the black dot on the input to the black dot on the output.
E Output List	List of the outputs on the device.
F Output Channels	Disabled on the soundbar set to Surround.
G Process	Toggle between Process or Pass-Through, this feature is disabled on the Speaker Out.
H Delay	Disabled on this tab. The Configuration Tab allows control of channel delay.
I Volume	Adjusts the volume level of the output channel. For speaker outputs, the possible adjustment range varies across different IP Audio devices. Changes are made in 1 dB increments.

## 7.5. Calibration Tab

The Calibration tab only found on IP Audio products that are WiSA certified.

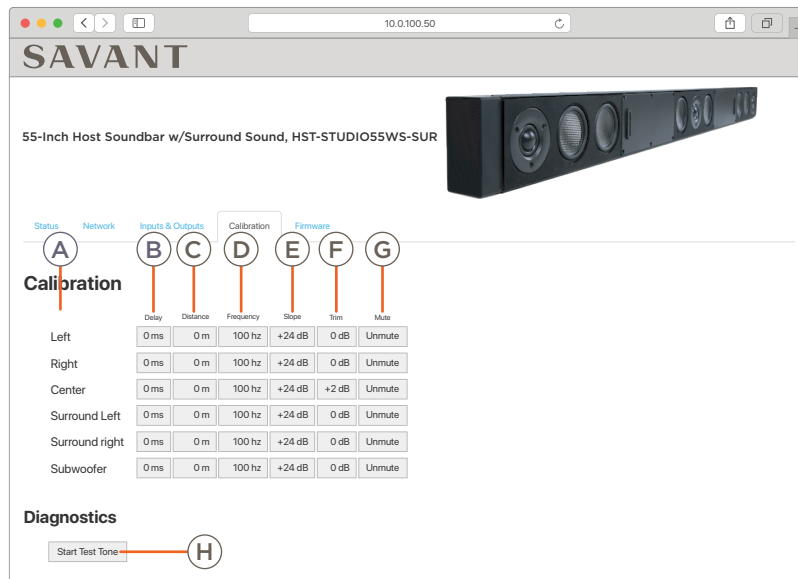

<b>(A)</b> Channel List	List of audio channels.
<b>(B)</b> Delay	Adjustable delay per channel from 0 - 160ms.
<b>(C)</b> Distance	Set the distance the speaker is from the listener. This setting can be set in feet or meters.
<b>(D)</b> Crossover Frequency	Crossover frequency - the limit to which audio can be played back through the speaker. For example, a subwoofer will roll off audio above the crossover frequency, and a mid-level speaker will roll off audio below the crossover frequency
<b>(E)</b> Slope	In audio filters, slope refers to how quickly frequencies are attenuated by the filter once the cutoff frequency is passed.
<b>(F)</b> Channel Trim	Adjusts the gain of the input from -10 dB to +10 dB. Trim settings on the HST-STUDIO55WS-SUR persist though reboots and Host uploads.
<b>(G)</b> Mute	Toggles Test Tone on or off for the selected channel.
<b>(H)</b> Test Tone	Toggles pink noise through all un-muted channels

**Speaker Distance** - Should be measured and set based on the ideal listener's seating location. This will automatically adjust the channel delay to allow the audio to be synced to the listener. This delay will be added to the time added to the Channel Delay field.

**Recommended Calibration Settings** - The table below shows the recommended settings for Crossover Frequency, Slope, and Channel Trim. These settings are intended to be a starting point for testing. Every individual will experience audio differently so what sounds good to the installer may not sound good to the user.

	Soundbar Only			WiSA Surrounds and Sub		
	Frequency	Slope	Channel Trim	Frequency	Slope	Channel Trim
Left	80 Hz	24 dB	0 dB	100 Hz	24 dB	0 dB
Right	80 Hz	24 dB	0 dB	100 Hz	24 dB	0 dB
Center	80 Hz	24 dB	+2 dB	100 Hz	24 dB	+2 dB
Surround Left				100 Hz	24 dB	0 dB
Surround Right				100 Hz	24 dB	0 dB
Subwoofer				100 Hz	24 dB	0 dB

## 7.6. Firmware Tab (Host <-> Subordinate Settings)

The Firmware tab will appear on all IP Audio products with Integrated Host using da Vinci 9.2 or Higher.

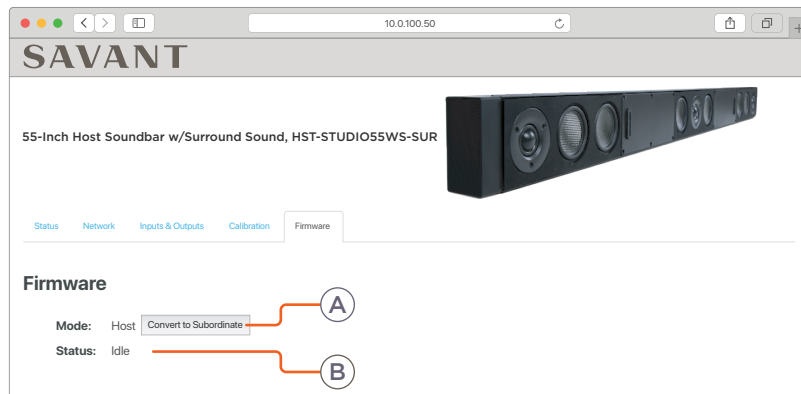

(A) Device Mode

Displays the current mode of the chassis.

Button reads Convert to Host or Convert to Subordinate. This will change the device's internal identity to allow it to take the required firmware for the desired function.

**NOTE:** Internet access is required for this process to complete.

(B) Device Status

Reports the status of the conversion process once initiated.



**IMPORTANT!** Converting a device from Host Mode to Subordinate Mode **MUST** be completed before it is placed on the same network as the Savant Host that has its UID in its configuration.

## Appendix A: Network Requirements

Savant requires the use of business class/commercial grade network equipment throughout the network to ensure the reliability of communication between devices. These higher quality components also allow for more accurate troubleshooting when needed.

### Device Network Connections

Connect all Savant devices to the same local area network (LAN) or subnet as the Host. Savant recommends not implementing any type of traffic management, packet shaping, band steering, QoS or similar features within the network topology for Savant devices, as this may interfere with performance.

### AVB Requirements

Savant requires the use of an AVB/TSN compliant switch meeting IEEE standard 802.1BA+2011 for all IP Audio components utilizing AVB communication.

### Managing IP Addresses

To ensure that the IP Address will not change due to a power outage, a static IP Address or DHCP reservation should be configured. Savant recommends using DHCP reservation within the router. By using this method, IP Addresses for all devices can be managed from a single UI avoiding the need to access devices individually.

#### Setting a Static IP Address

Setting a Static IP Address can be done in the Web UI on the Network Tab.

#### Setting DHCP Reservation

Setting DHCP reservation varies from router to router. Refer to the documentation for the router to configure DHCP reservation.

### Network Changes

Savant recommends performing one of the following steps to refresh the IP connection after connecting to a new network, changing routers, or if the IP Address range is changed in the current router. This will reset any IP connection and ensure that the Host is communicating with the network correctly.

#### Cycle Power

- Disconnect the IP Audio device from the power source.
- Wait 15 seconds and then reconnect.

#### Hot Plug the Ethernet (LAN) Connection

- Disconnect the Ethernet (LAN) connection from the device.
- Wait 15 seconds and then reconnect.

## Appendix B: System Monitor - Savant Music Trim

Input trim of the Savant Music 2.0 service can be adjusted from within System Monitor. The trim adjustment is from 0 dB to -12 dB. Below is an image of the Music Service System Monitor screen.

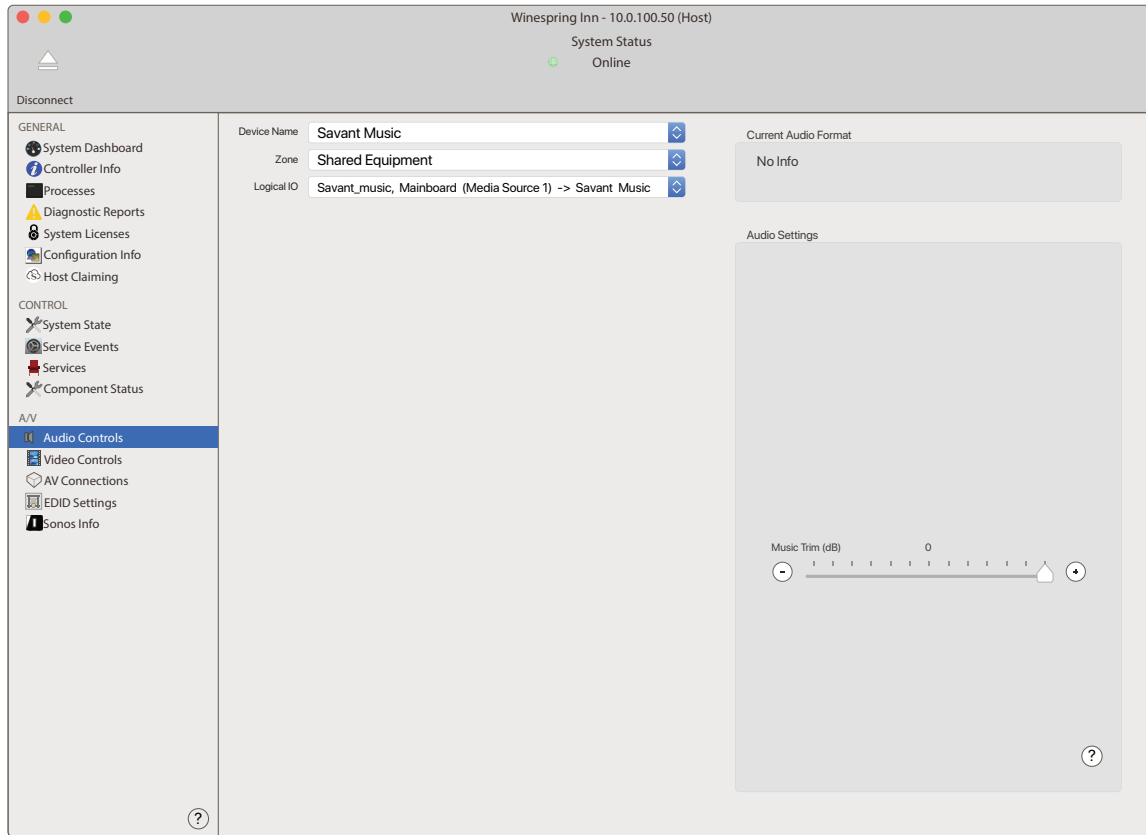

# Important Notice

## Disclaimer

Savant Systems, Inc. reserves the right to change product specifications without notice, therefore, the information presented herein shall not be construed as a commitment or warranty.

Savant Systems, Inc. shall not be liable for any technical or editorial errors or omissions contained herein or for incidental or consequential damages resulting from the performance, furnishing, reliance on, or use of this material.

The Spotify Software is subject to third party licenses found here: <https://www.spotify.com/connect/third-party-licenses>.

## Patents

Certain equipment and software described in this document is protected by issued and pending U.S. and foreign patents.

All products and services are trademarks or registered trademarks of their respective manufacturer.

## Copyright

This document contains confidential and proprietary information protected by copyright. All rights reserved. Copying or other reproduction of all or parts of this document is prohibited without the permission of Savant Systems.

## Trademarks

© 2021 Savant Systems, Inc. All rights reserved. Savant, Savant App, Truelmage, Savant Host, Now You Can, RacePoint Blueprint, Single App Home, TrueCommand, TrueControl, and the Savant logo are trademarks of Savant Systems, Inc.

AirPlay, Apple, AirPort Express, AirPort Extreme, Apple TV, Apple Remote Desktop, FireWire, iMac, iTunes, iPad, iPad mini, iPad Air, iPhone, MacBook, Mac and OS X are trademarks or trade names of Apple Inc. iOS is a trademark of Cisco®. Android, Google, Google Play, and other Google marks are trademarks of Google, Inc. Wi-Fi is a registered trademark of the Wi-Fi Alliance®. HDMI® is a trademark of HDMI Licensing, LLC. MOTU® is a registered trademark of Mark of the Unicorn, Inc. Luxul is a registered trademark of Luxul Wireless. NETGEAR®, the NETGEAR Logo and ProSAFE are trademarks of NETGEAR, Inc. Extreme™ is a trademark of Extreme Networks, Inc.

All other brand names, product names, and trademarks are the property of their respective owners.

## Technical and Sales Support

Savant Systems, Inc is dedicated to providing prompt and effective support in a timely and efficient manner.

- To contact Savant Support, access the **Savant Customer Community** and enter a support Case ticket.
- To contact Savant Sales, visit Savant.com and select Contact Us to locate a local sales representative in your area.